

Beispiel: Variante V09 ( 1 : 2 )  
 Variante: W-2044586-V09 / ZB Schmiermittelbehälter 5,0-VA-2NC

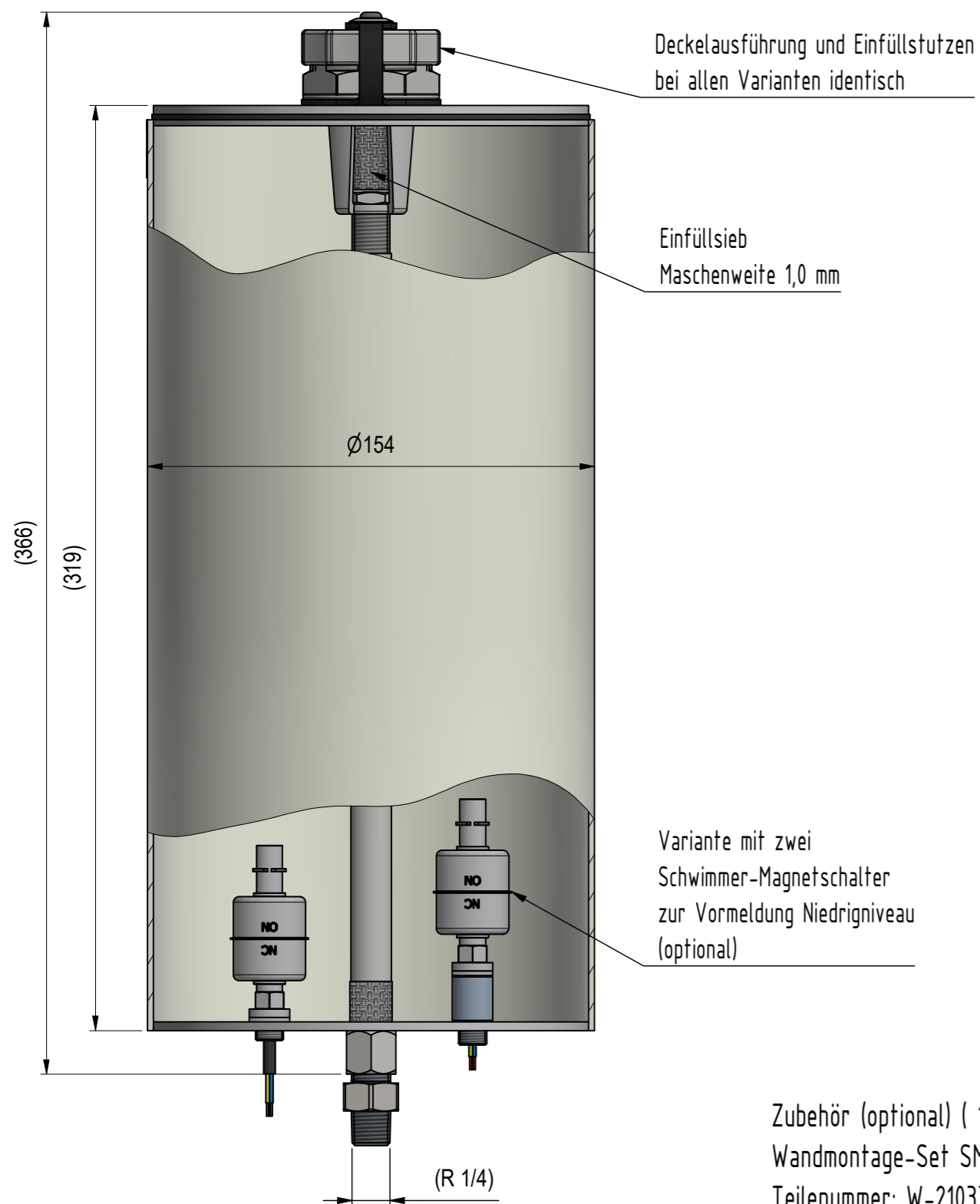

Beispiel: Variante V05 ( 1 : 2 )  
 Variante: W-2044586-V05 / ZB Schmiermittelbehälter 3,0-VA-NC

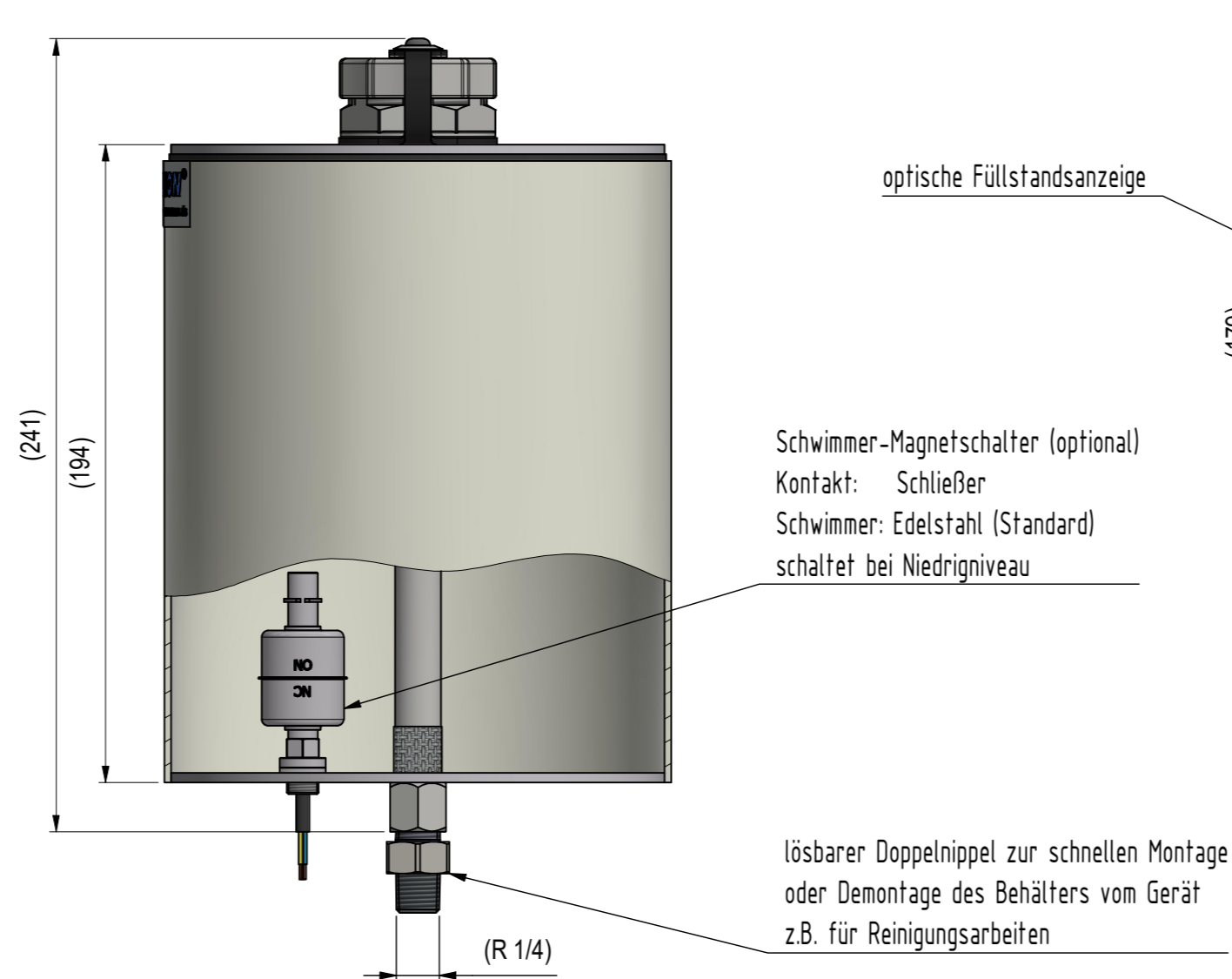

Beispiel: Variante V01 ( 1 : 2 )  
 Variante: W-2044586-V01 / ZB Schmiermittelbehälter 2,0-VA

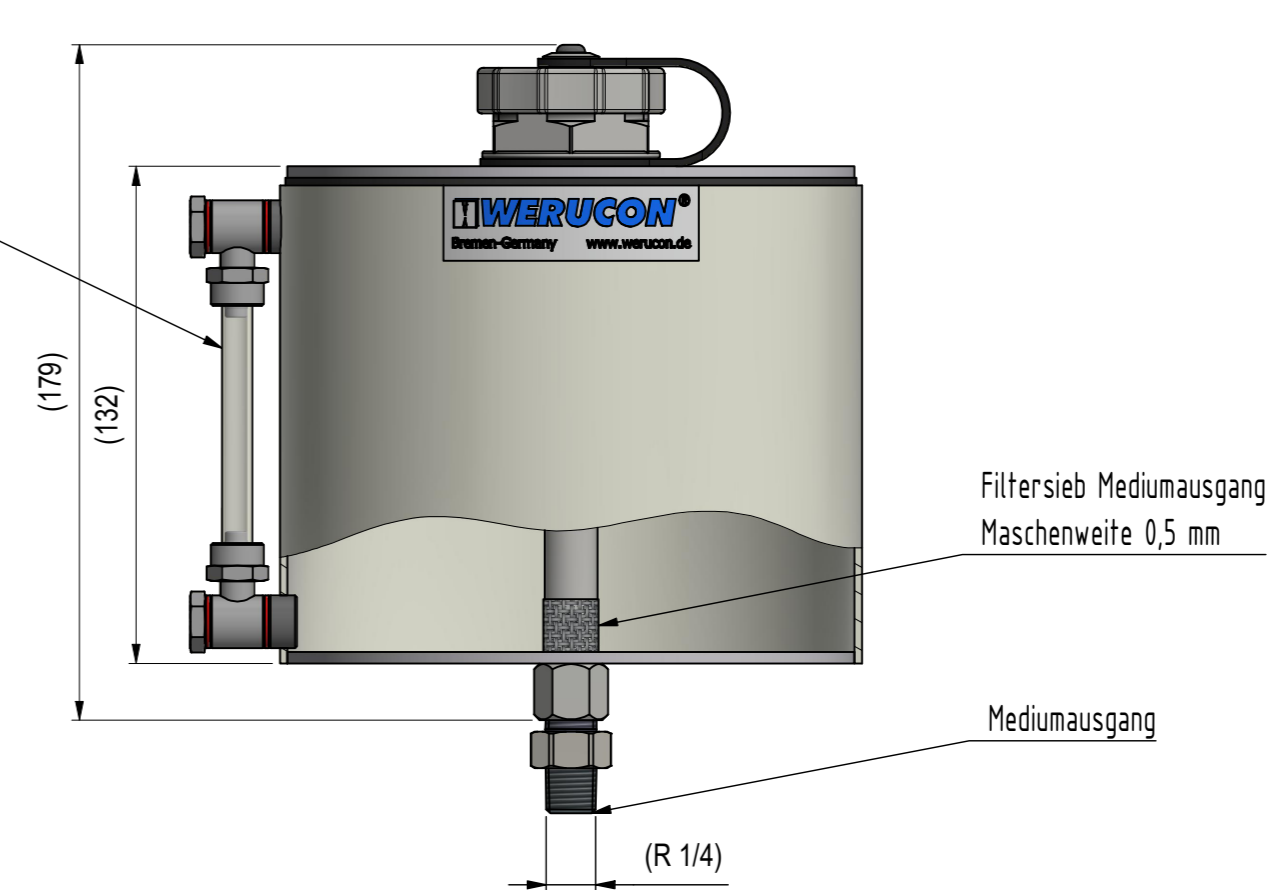

Darstellung ohne Deckel ( 1 : 2 )

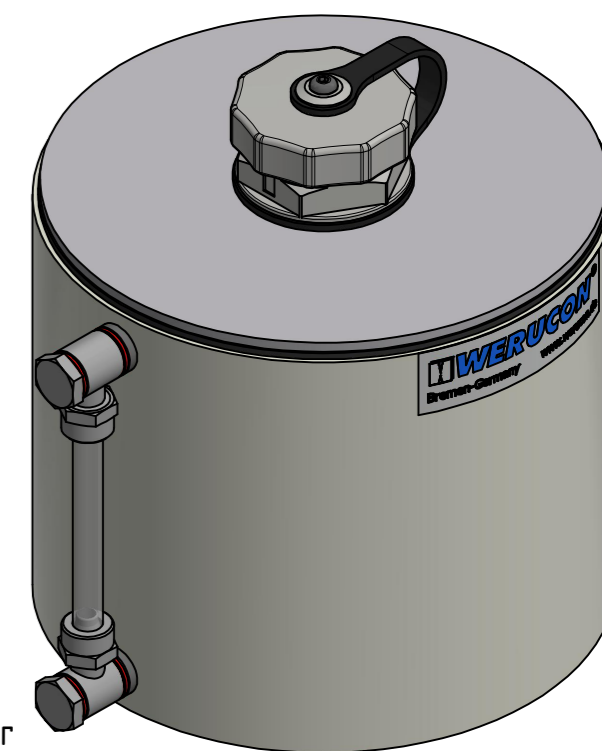
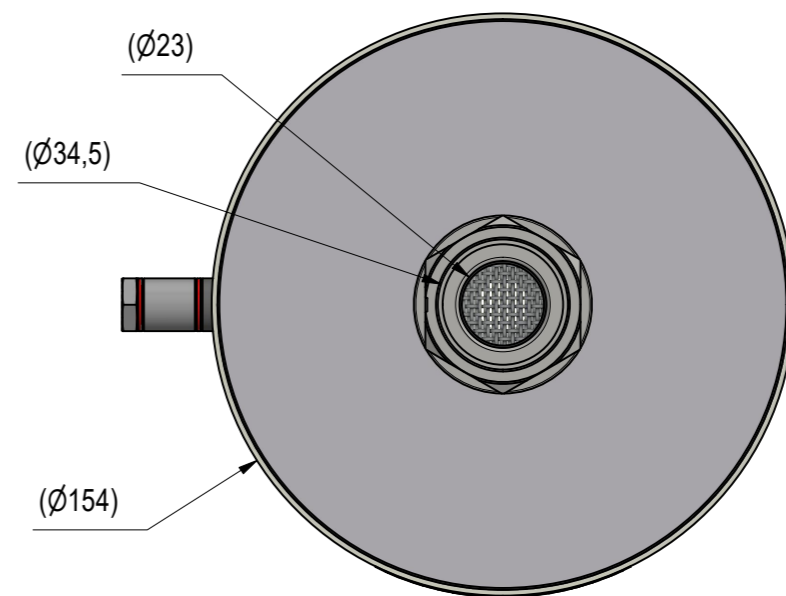

Zubehör (optional) ( 1 : 2 )  
 Wandmontage-Set SMB4  
 Teilenummer: W-2103390

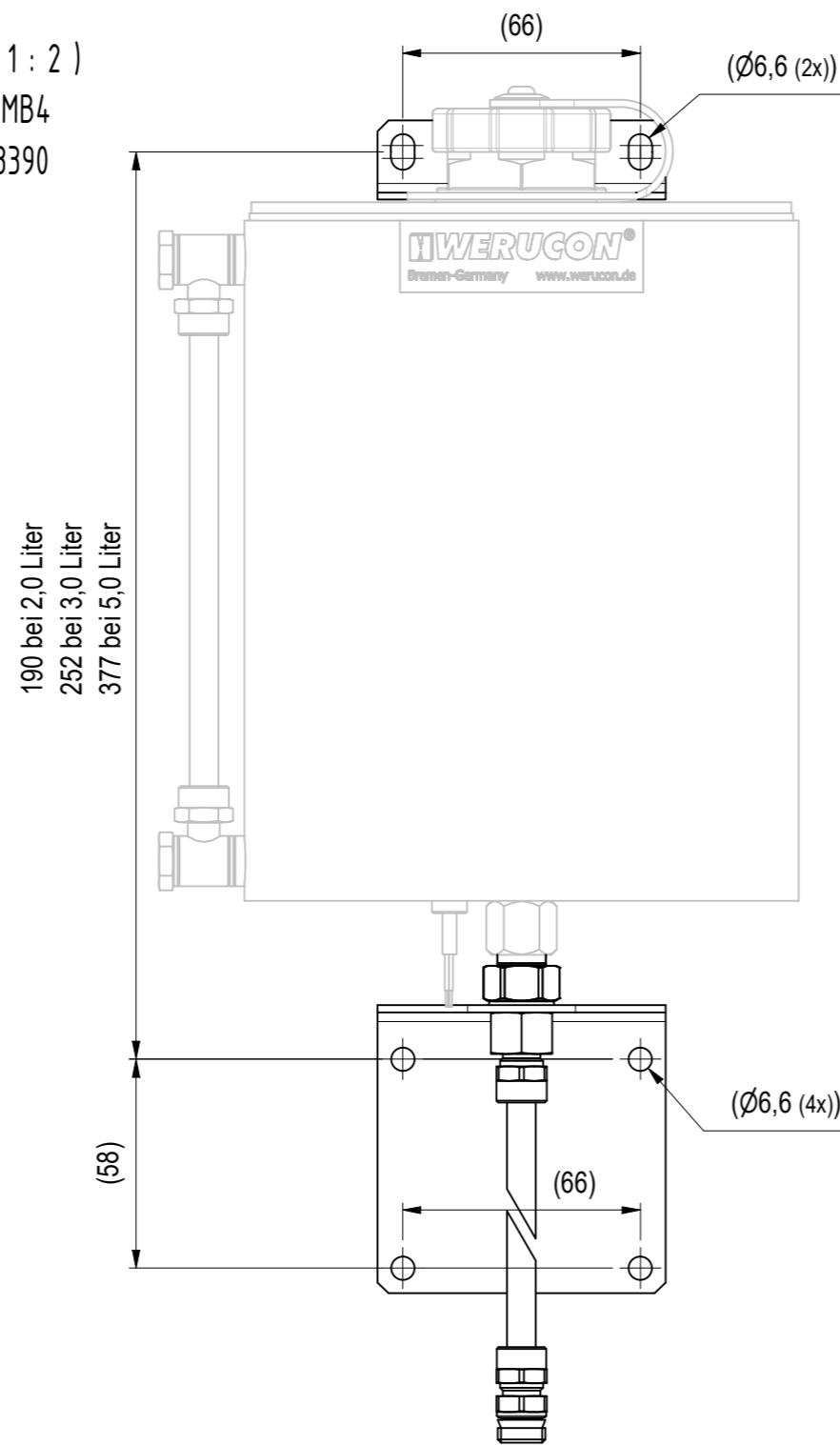

**Bestellschlüssel:**

**SMB4 - 3,0 - VA - NC**

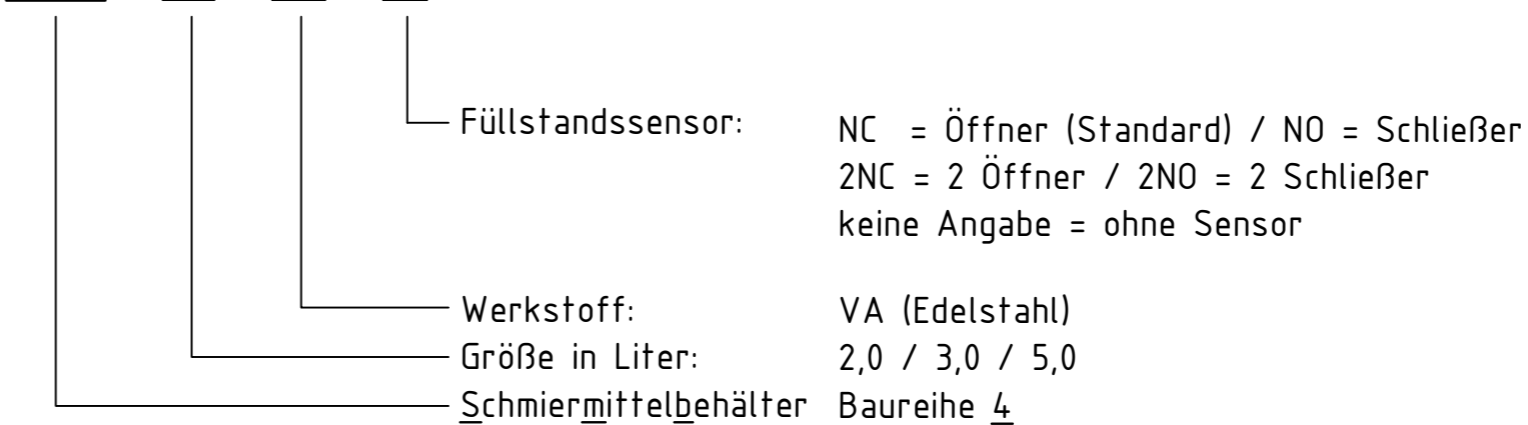

**Technische Beschreibung**

- Behälterausführung in Edelstahl
- Drucklose Schmierstoffversorgung von Dosiergeräten
- Wartungsfreundlich, schnelle Montage und Demontage des SMB möglich!
- Leergewicht: 2,2 / 2,8 / 3,8 kg

**Werkstoffe**

- Behälterbauteile: Edelstahl
- Doppelnippel, lösbar: Messing, vernickelt

|   |  |  |  |  |                         |
|---|--|--|--|--|-------------------------|
| © The reproduction, distribution and utilization of this document as well as the communication of its contents to others without express authorization is prohibited. Offenders will be held liable for the payment of damages. All rights reserved in the event of the grant of a patent, utility model or design. |  | Toleranzangaben / Tolerance Data<br>DIN ISO 2768 - mH DIN EN ISO 1302<br>Bohrungen und Gewinde / drillings and threads $\pm 0,1$<br>Passbohrungen / precision drillings $\pm 0,01$ |  | gezeichnet / drawn: 08.03.2023 Meyer                             | kontrolliert / checked: |
| Modell / part: 11.01.2023 Meyer   |  | Bezeichnung / designation<br>- Technische Beschreibung -   |  | ZB Schmiermittelbehälter vst<br>assembly lubricant tank complete |                         |
| WERUCON®<br>WERUCON GmbH / Bremen - Germany<br>Nantes-Strasse 3, 28309 Bremen   |  | Anzahl   |  | Produkt - Baugruppe / product - assembly<br>SMB4 - 00            |                         |
| Telefon: +49 421 223085-0 / Fax: +49 421 223085-99<br>E-Mail: info@werucon.de<br>Internet: www.werucon.de   |  | letzte Sicherung / last save<br>16-05-2023<br>06:48:49   |  | Artikel / article<br>Teilenummer / part number<br>W-2044586-Tab  |                         |
| Keine Änderung ohne Zustimmung der federführenden Konstruktion. / Any alterations are subject to the approval of the design department.   |  |  |  |  |                         |

| Nr.-No.                              | Änderung - Alteration | Datum - Date | Name |
|--------------------------------------|-----------------------|--------------|------|
| Revisions-tabelle - Revision History |                       |              |      |