

variant table	
part number	designation
W-2053174-V01	stainless steel pressure tank 25L
W-2053174-V02	stainless steel pressure tank 25L NC
W-2053174-V03	stainless steel pressure tank 25L NO
W-2053174-V04	stainless steel pressure tank 25L 2x NC
W-2053174-V05	stainless steel pressure tank 25L 2x NO

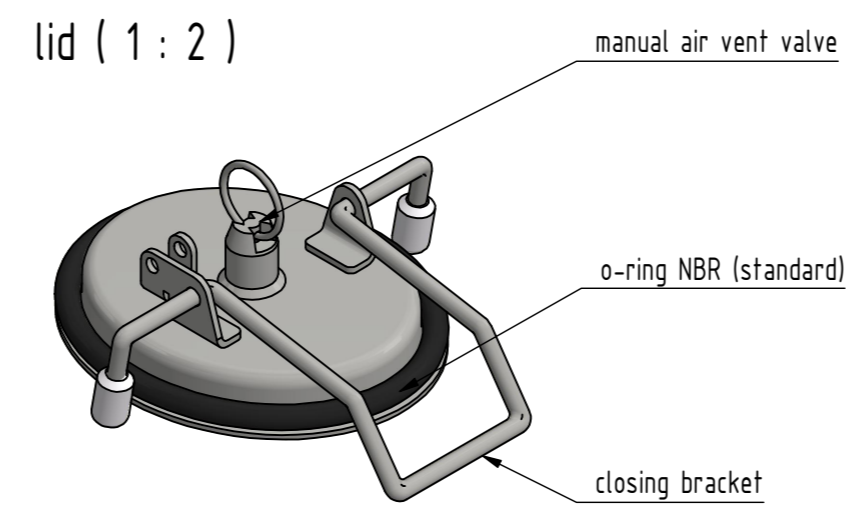

accessories (optional) (1 : 5)
 clamp 220
 part number: W-2005882

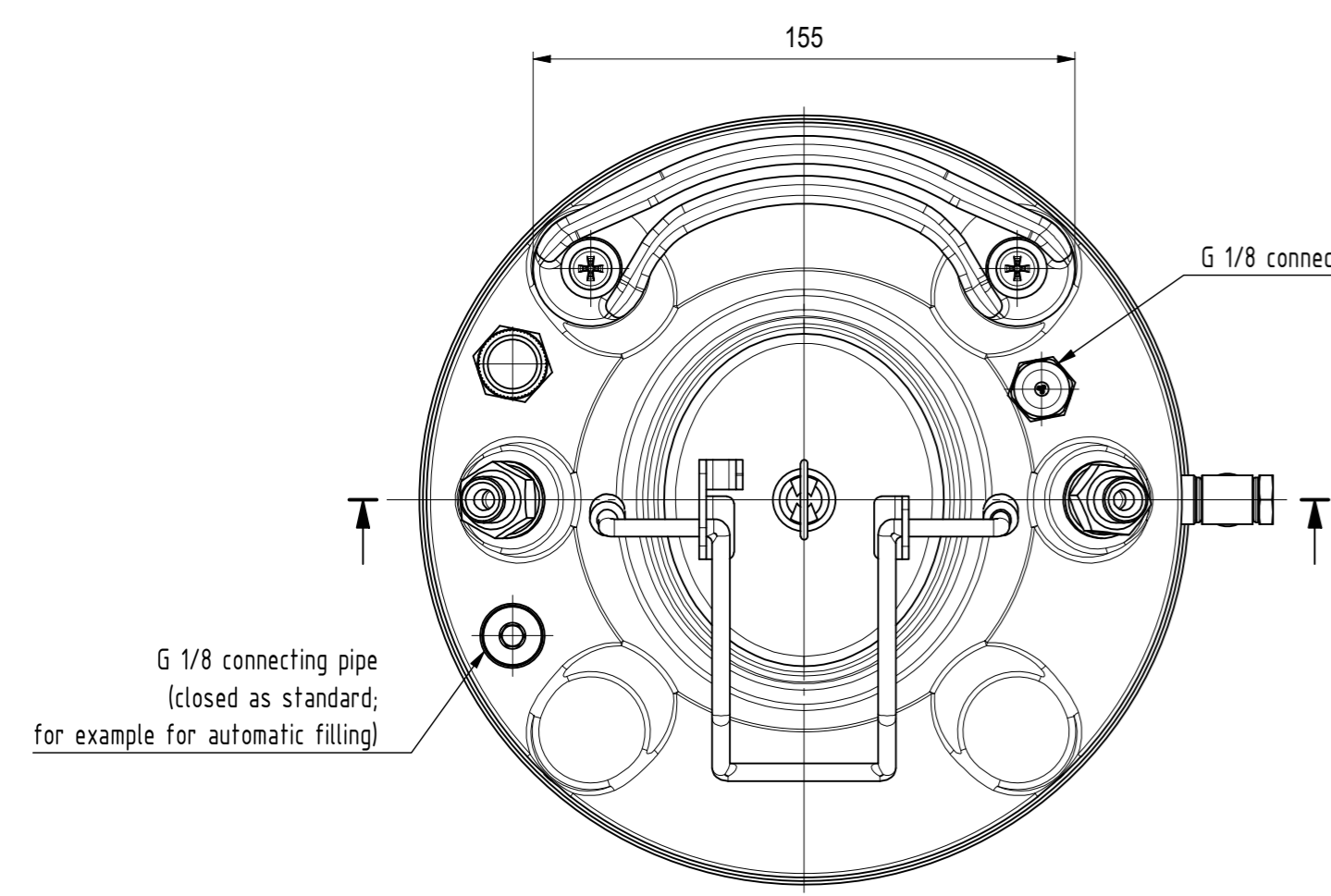
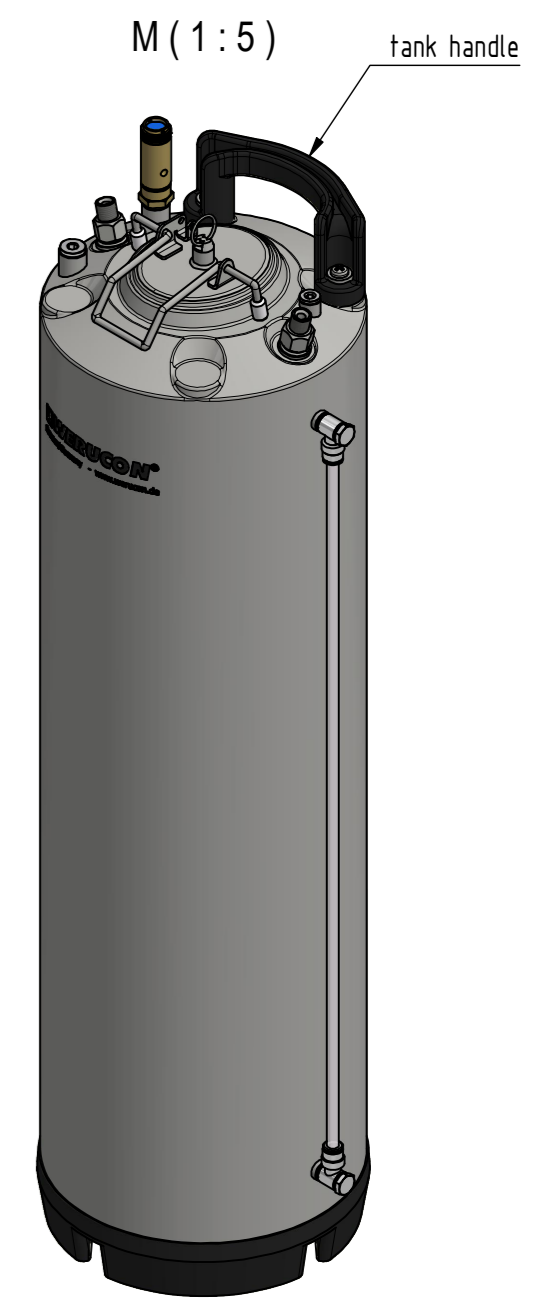
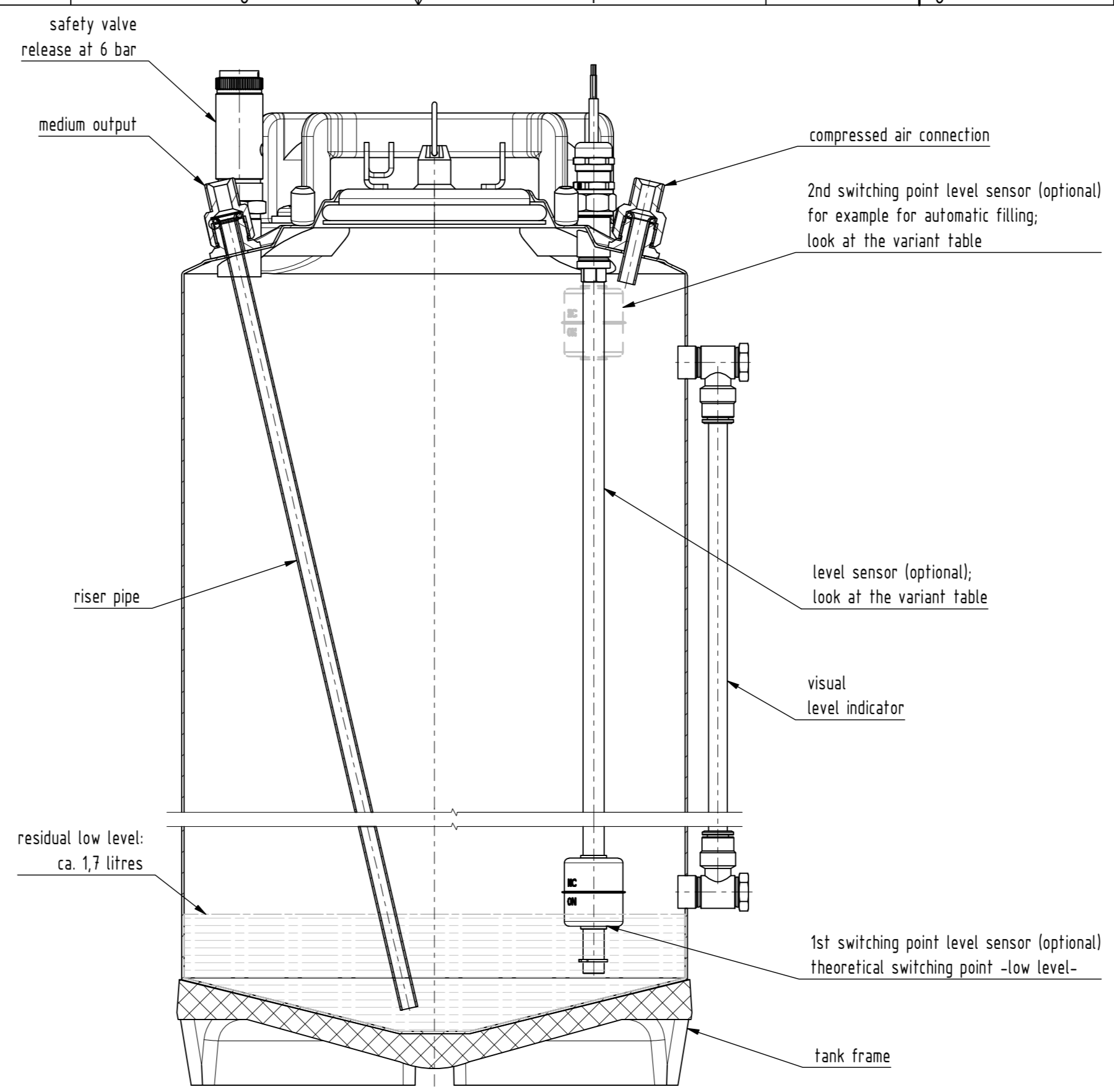
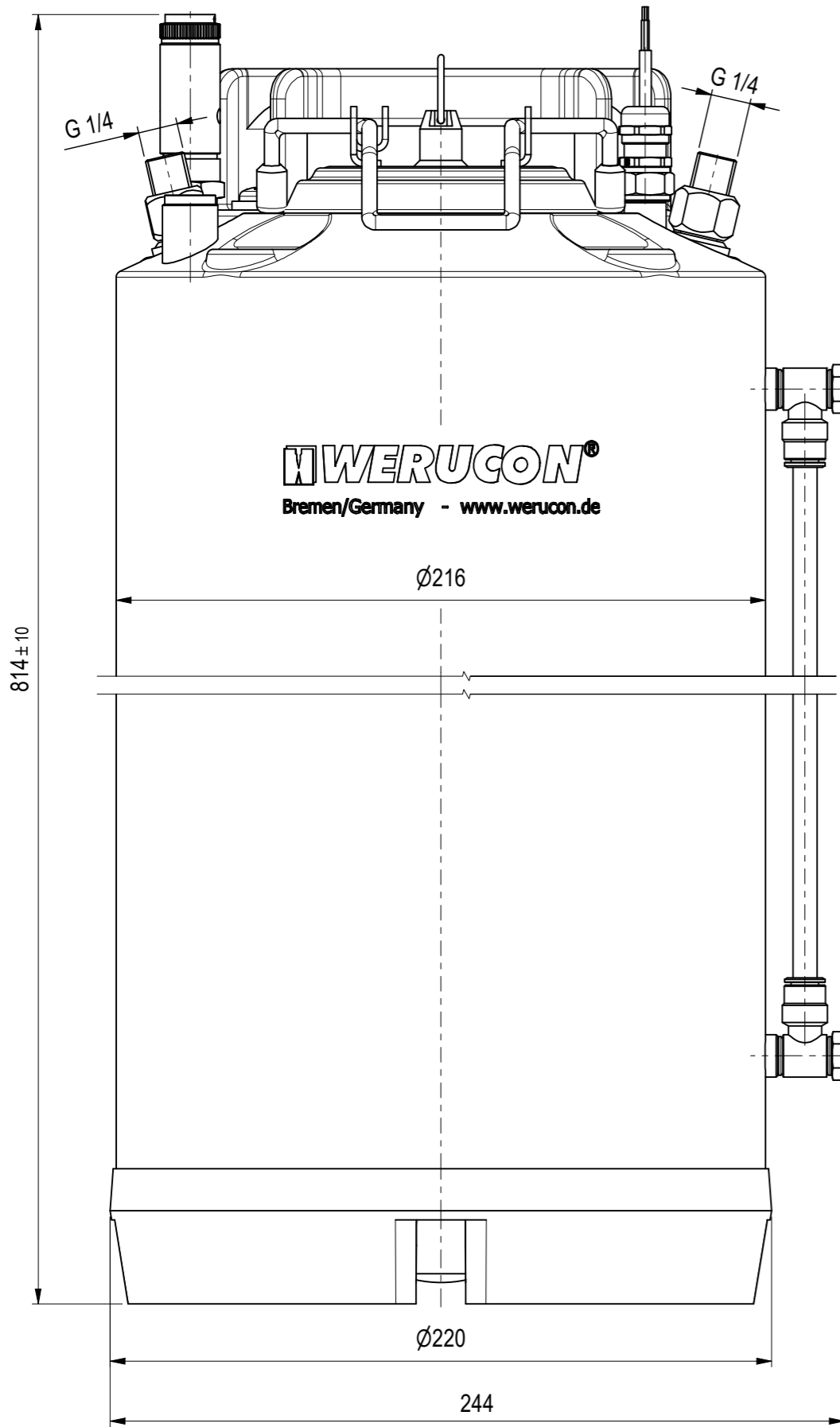
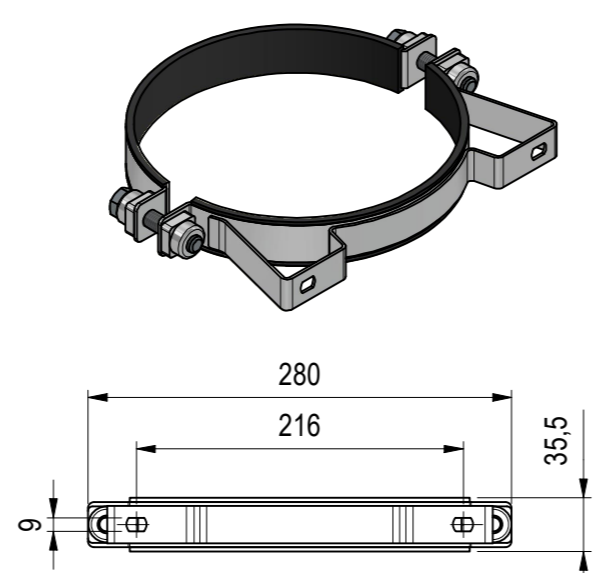

technical description

- content: 25 litres
- max. working pressure: 6 bar
- empty weight: 5,2 kg
- fluid group: 1

materials

- tank: 1.4301
- tank frame: SBR
- seals: NBR
- optional on request: Viton®

Toleranzangaben / Tolerance Data		Bohrungen und Gewinde / drillings and threads $\phi \pm 0,1$		Passbohrungen / precision drillings $\phi \pm 0,01$	
Model / part: 11.02.2022 Meyer	gez. / drawn: 22.12.2022 Meyer	kontr. / checked:		Format / size: A2	Blatt / sheet: 1/1
		Bezeichnung / designation: -technical description-			
WERUCON GmbH / Bremen - Germany Nantes-Strasse 3, 28309 Bremen		Edelstahl-Druckbehälter 25L stainless steel pressure tank 25L			
Telefon: +49 421 223085-0 / Fax: +49 421 223085-99 E-Mail: info@werucon.de Internet: www.werucon.de		letzte Sicherung / last save: 22-12-2022 10:42:07		Artikel / article: EDB2 - 00 Teilenummer / part number: W-2053174-Tab	
Keine Änderung ohne Zustimmung der federführenden Konstruktion. / Any alterations are subject to the approval of the design department.					

Nr.-No.	Änderung - Alteration	Datum - Date	Name
Revisions-tabelle - Revision History			