

variant table	
part number	designation
W-2053094-V01	stainless steel pressure tank 10L
W-2053094-V02	stainless steel pressure tank 10L NC
W-2053094-V03	stainless steel pressure tank 10L NO
W-2053094-V04	stainless steel pressure tank 10L 2x NC
W-2053094-V05	stainless steel pressure tank 10L 2x NO

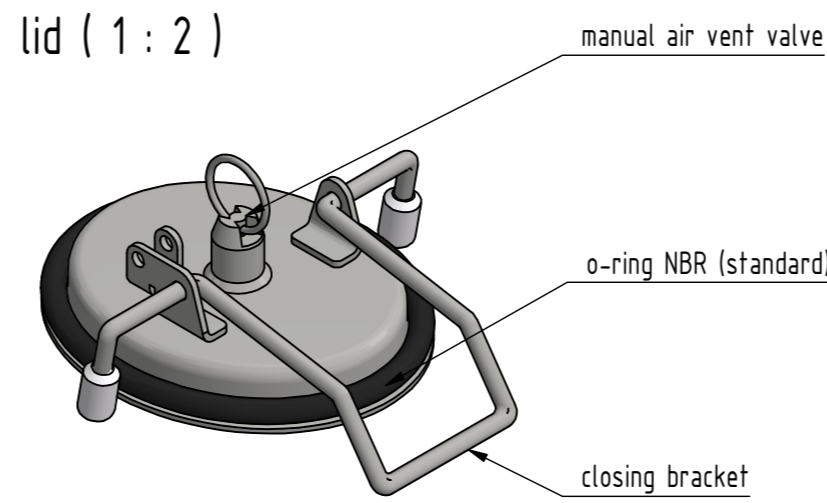

accessories (optional) ( 1 : 5 )  
 clamp 220  
 part number: W-2005882

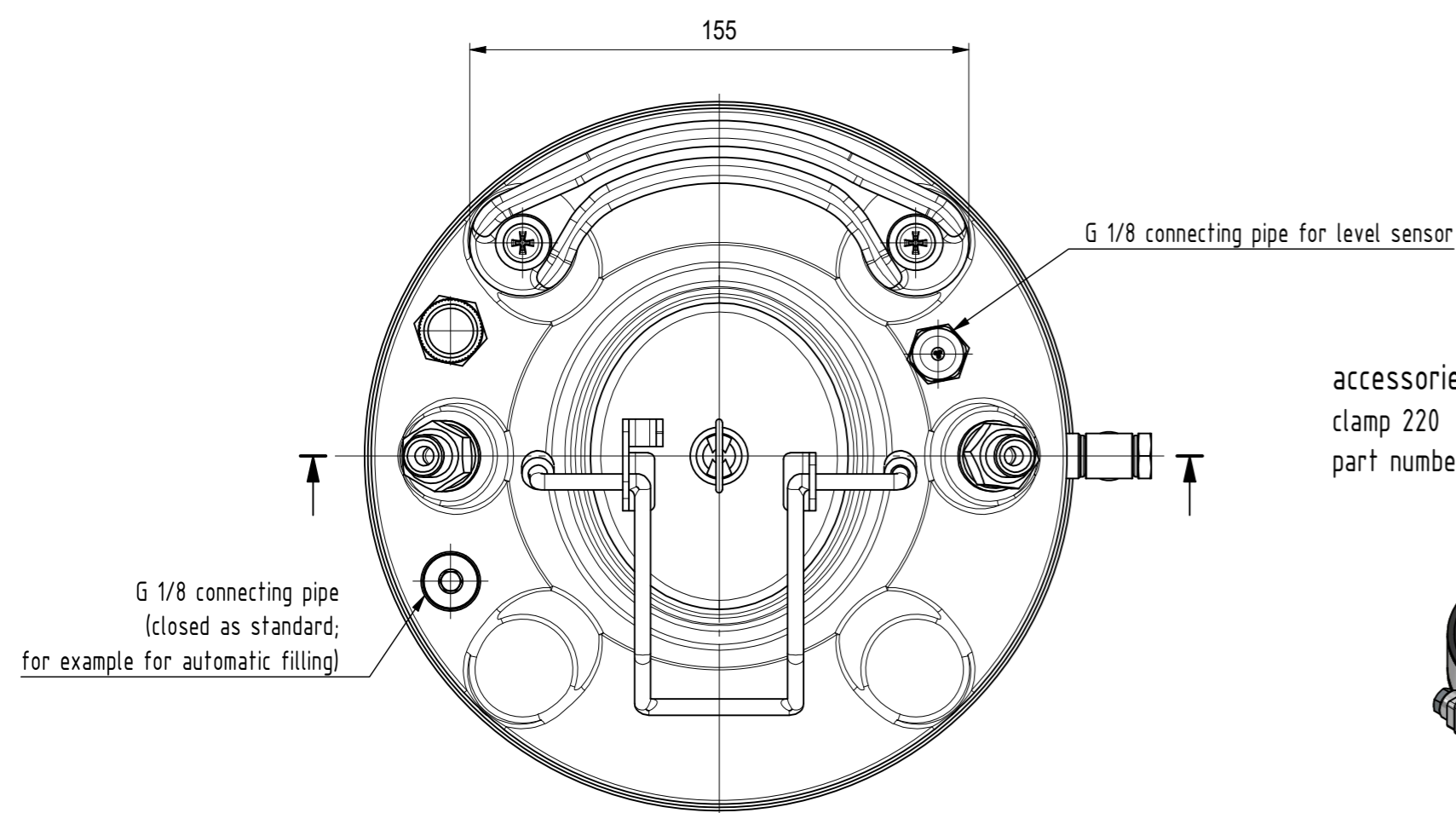
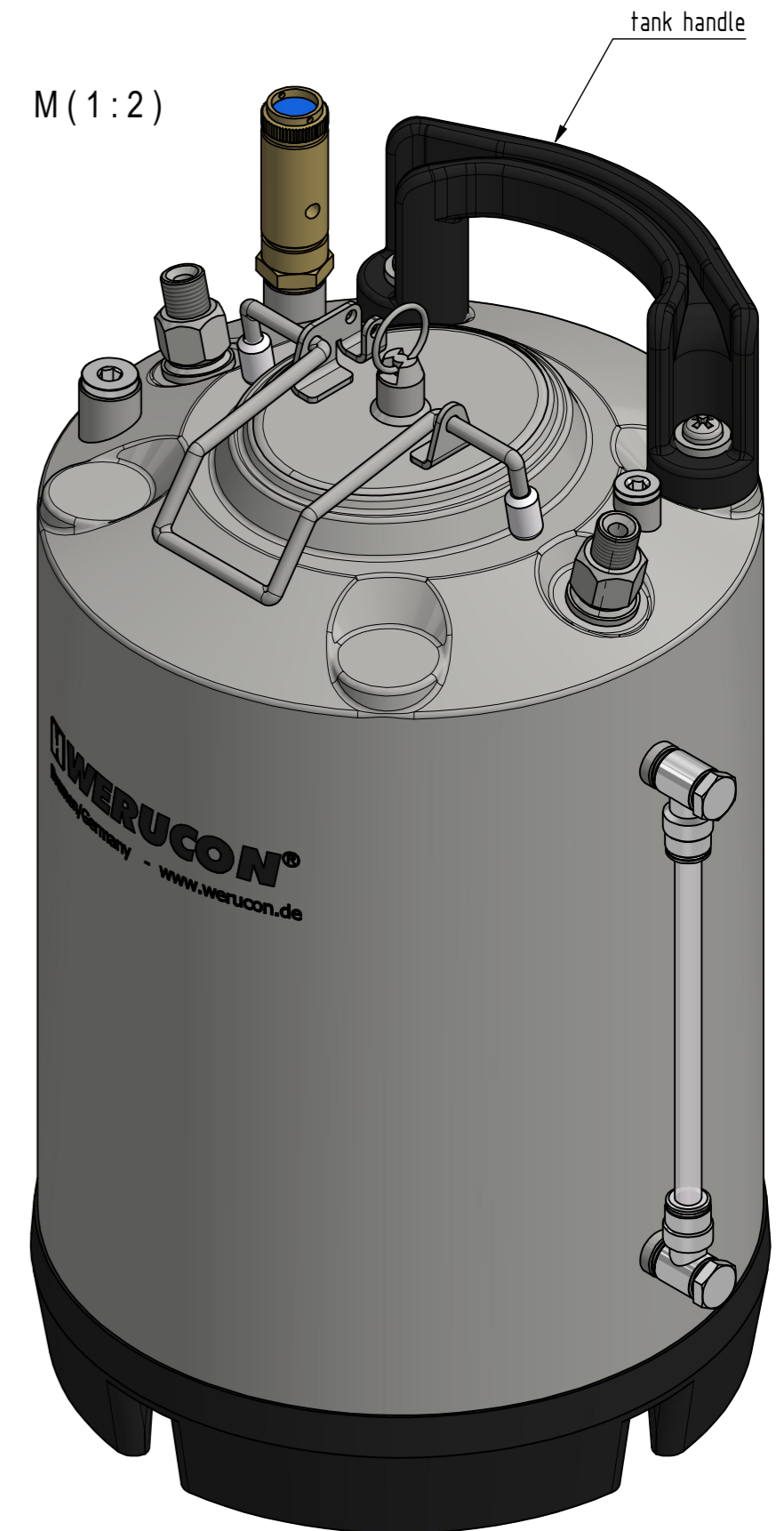
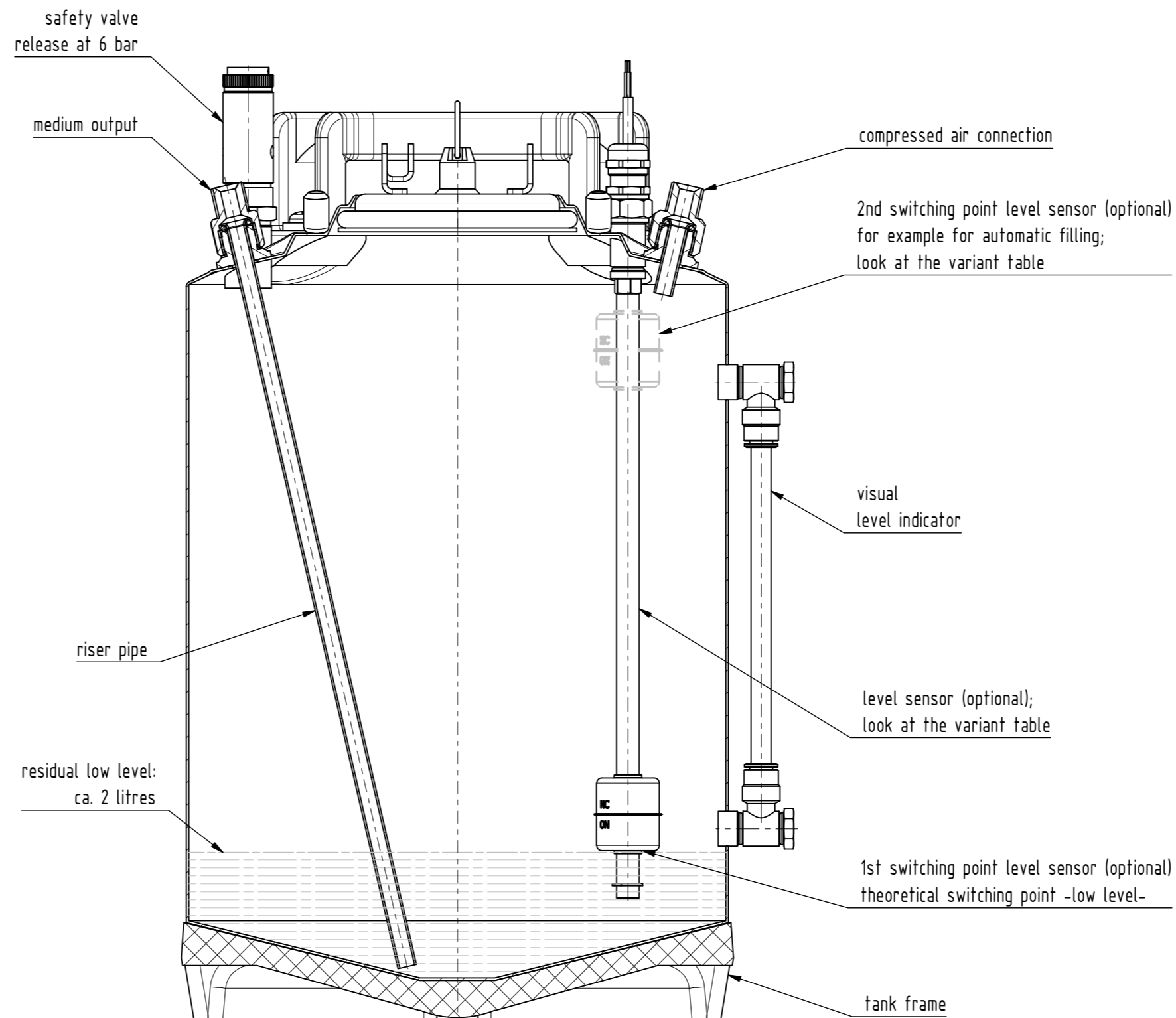
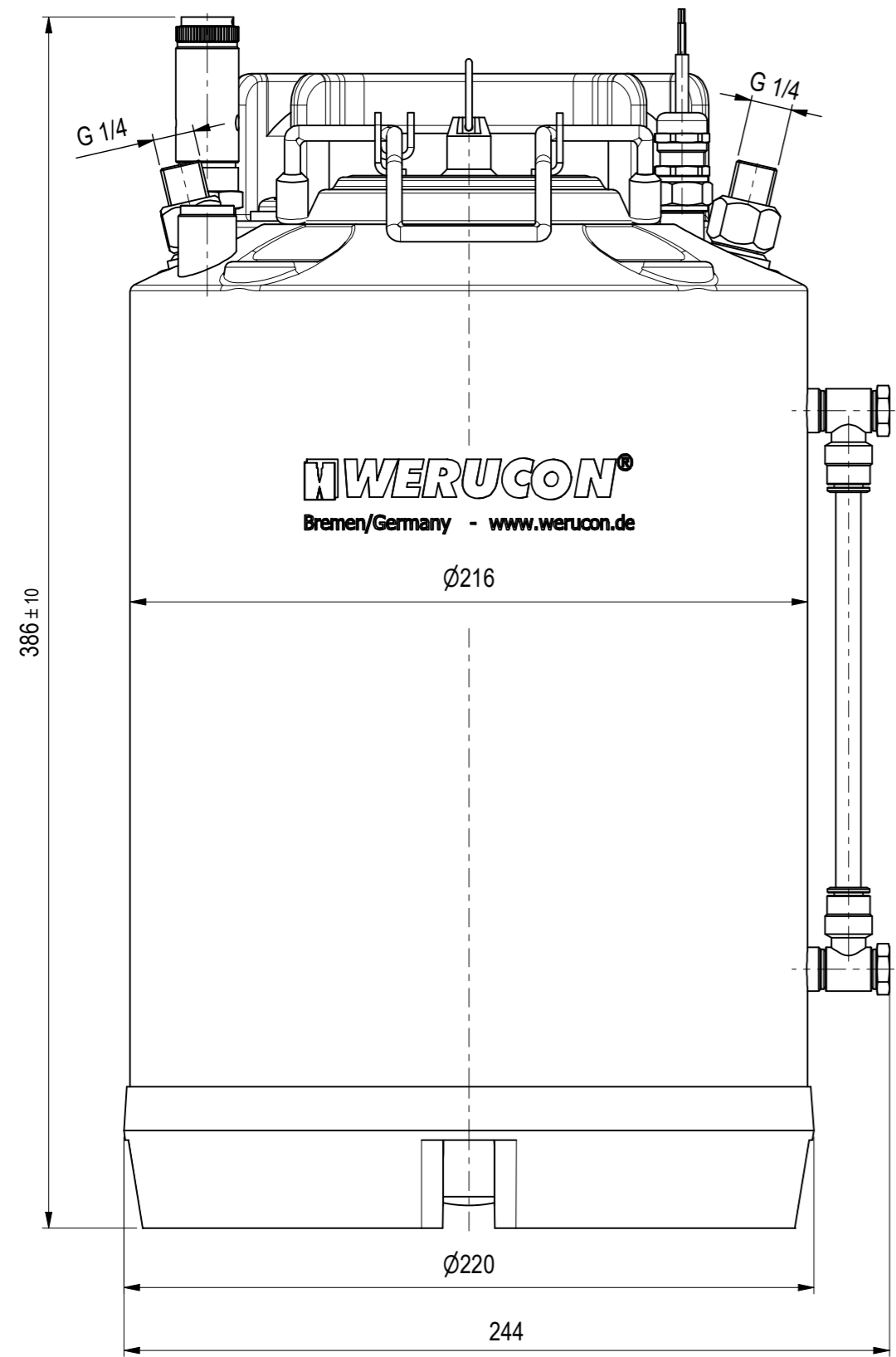
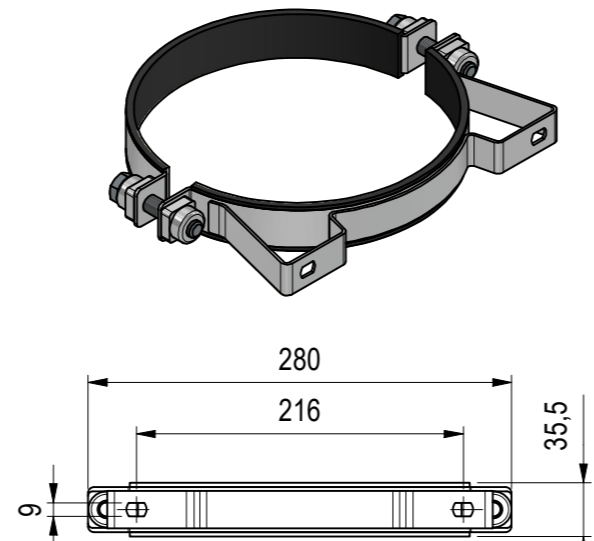

**technical description**

- content: 10 litres
- max. working pressure: 6 bar
- empty weight: 2,8 kg
- fluid group: 1

**materials**

- tank: 1.4301
- tank frame: SBR
- seals: NBR
- optional on request: Viton®

Toleranzangaben / Tolerance Data		Bohrungen und Gewinde / drillings and threads $\phi \pm 0,1$		Passbohrungen / precision drillings $\phi \pm 0,01$	
DIN ISO 2768 - mH		DIN EN ISO 1302			
Model / part: 08.02.2022 Meyer		gez. / drawn: 03.03.2022 Meyer		kontr. / checked:	
Intern		Bezeichnung / designation			
WERUCON®		Edelstahl-Druckbehälter 10L			
WERUCON GmbH / Bremen - Germany		stainless steel pressure tank 10L			
Nantes-Strasse 3, 28309 Bremen		Durchlauf-Sprühsystem			
Telefon: +49 421 223085-0 / Fax: +49 421 223085-99		letzte Sicherung / last save		Teilenummer / part number	
E-Mail: info@werucon.de		16-12-2022		EDB2 - 00	
Internet: www.werucon.de		12:12:12		W-2053094-Tab	
Keine Änderung ohne Zustimmung der federführenden Konstruktion. / Any alterations are subject to the approval of the design department.					

Nr.-No.	Änderung - Alteration	Datum - Date	Name
Revisions-tabelle - Revision History			