

# Mikro Dosing-Box

## Typ: MDB

### Application:

In general the Micro-Dosing-Box is used in Minimal Quantity Lubrication (MQL) in the cutting and non-cutting metal processing.

The liquid lubricant is being dosed and transferred fog-free to the contact-zone as a micro-fine lubricant-air-mixture, where it reduces considerably friction and heat.

The MQL is defined as a lubricant-throughput not exceeding 50ml per working-hour. Due to its wide adjustment-range of each lubricant-pipeline the Micro-Dosing-Box can supply even more than 200ml medium per working-hour, and therefore can also be used in other applications, such as the coating of large surfaces.

Other liquid mediums besides the conventional lubricants can also be used, provided that they are applicable to the Micro-Dosing-Box and recommended by WERUCON!



### Technical Description:

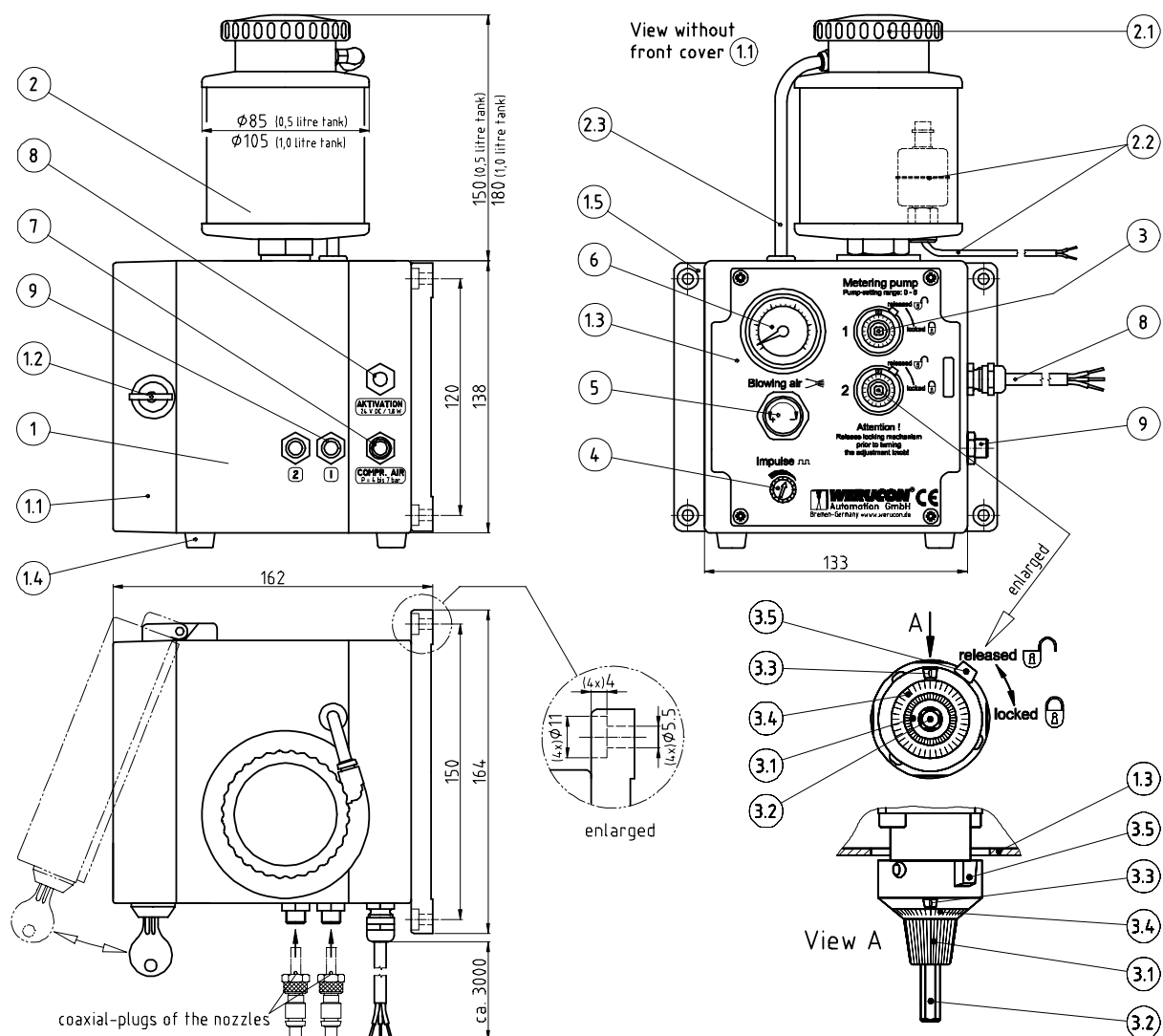

## Typ: MDB

Pos	Name	Discription / Function	Material
<b>1</b>	<b>Housing</b>		ABS (grey, similar. RAL 7035)
1.1	Front Cover	- lockable door for control panel	PC (transparent)
1.2	Lock	- incl. two keys	Brass (nickel-plated)
1.3	Control Panel	- panel for adjustment and controlling	Al (silver anodised)
1.4	Base	- for usage as a stand-up-unit	Rubber (black)
1.5	Frame	- for installation on a wall	ABS (graphit-grey, sim.. RAL 7024)
<b>2</b>	<b>Lubricant tank</b>	- 0,5 litre / 1,0 litre - optional using aggressive mediums: tank=glas and sealing=FKM / PTFE	PC / Glas (transparent) Brass (nickel-plated) NBR / FKM / PTFE
2.1	Lid	- to close the lubricant-entry	Brass (nickel-plated), NBR
2.2	Level Sensor (optional)	- only available with 1,0 litre - magnetic sensor - 2 m cable, 2-core - max. 300 V (AC/DC), max. 30 VA, max. 0,5 A	Stainless steel Cable: PVC
2.3	Bleed Hose	- for manual bleeding of the metering pump(s)	PA (transparent)
<b>3</b>	<b>Metering Pump</b>	- pneumatic; min. air-pressure = 4 bar - max. throughput = 35 mm <sup>3</sup> /stroke - min. pressure = 66 bar (4 bar air-pressure) - max. pump-frequency = 120 stroke/min - max. 2 Metering pumps per MDB	Brass (nickel-plated), stainless Steel, PTFE, FKM, NBR, POM
3.1	Adjustment Knob	- throughput-adjustment: 0 bis 35 mm <sup>3</sup> /stroke	
3.2	Manual Valve-Operation	- visual control / manual operation	
3.3	Scale	- dial setting: 1 bis 6 turns	
3.4	Fine Scale	- each unit 0,02	
3.5	Scale-Lock	- locking lever	
<b>4</b>	<b>Pulse Generator</b>	- pump-frequency: 1 bis 120 stroke/min - basic setting ca. 40 stroke/min	
<b>5</b>	<b>Pressure-RegulatingValve</b>	- intensity of blowing air - normal: 0,2 bis 0,8 bar - except: "Drip-Stop"-nozzle more than 3 bar	
<b>6</b>	<b>Pressure gauge</b>	- displays the blowing-air intensity	
<b>7</b>	<b>Pressure Supply</b>	- 3 m hose (ø6) with plug connector (DN 7,2) - pressure: 4 bis 7 bar - oil-free + filtered (10 µm)	PUR
<b>8</b>	<b>Activation</b> (optional: pneum. / electr.)	- monostable activation (elektr. / pneum.) - electr.: 24 V DC / 24 V AC / 110 V AC / 230 V AC 3 m cable, 3-core - pneum.: Min. 4 bar; oil-free + filtered (10 µm) 3m hose (ø 4)	Cable: PVC Hose: PUR
<b>9</b>	<b>Coaxial Housing Connection</b>	- connection of metering-nozzles - max. 2 housing connections <sup>1)</sup> possible	Brass (nickel-plated), stainless steel, FKM

### Function:

The lubricant flows out of the tank (2) to the Metering-pumps (3) due to gravity feed and pump suction. The pumps are pneumatically driven. When compressed air is applied to the Metering-pump, displacement piston is driven forward pushing the chosen amount of lubricant through a non-return-valve on the outlet side of the pump. After pneumatically switching over the spring-loaded piston returns to its zero-position. This procedure is continually being repeated by the adjustable pulse-generator (4). The stroke depth of the piston as well as the amount of lubricant per stroke can be set infinitely using the adjusting knob (3.1).

The lubricant is driven from the Metering-pump outlet (3) to the centre of the coaxial housing connection (9). The compressed air regulated by the pressure regulating valve (5) is transferred radially to the coaxial housing connection (9).

The Coaxial-plug<sup>2)</sup> (quick release) connects the Metering-nozzle<sup>2)</sup> with the coaxial housing connection (9) via hose line<sup>2)</sup>. The mediums/substances of lubricant and compressed air are being conveyed separately to the jet of the Metering-nozzle<sup>2)</sup>. The hose (set)<sup>2)</sup> consists of an inner- and outer-hose. The inner-(centre-) hose conveys the lubricant, the outer one the compressed air.

## Typ: MDB

The lubricant outlet port is located in the centre of the Metering-nozzle<sup>2)</sup>. The compressed air is being transferred around this port via a defined ring-shaped passage. Due to this type of nozzles an extraordinary well reproducible, fine sprayed cone of a lubricant-air-mixture is formed not before the jet of the Metering-nozzle<sup>2)</sup>. For each individual use the size of the sprayed cone can be altered by the pressure regulating valve (5).

### Throughput of the Metering-pump:

The graphs below are theoretical. The real throughput can vary slightly due to different viscosities, hose-lengths, temperatures etc.

graph.1: Throughput per stroke with various settings.

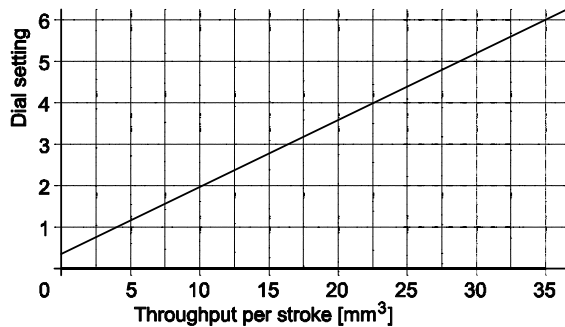

graph.2: Throughput per hour with various settings and frequencies.

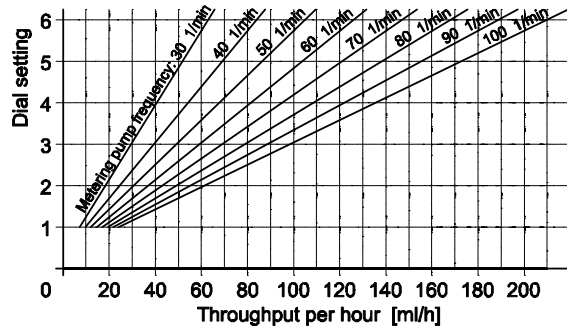

### Order-code:

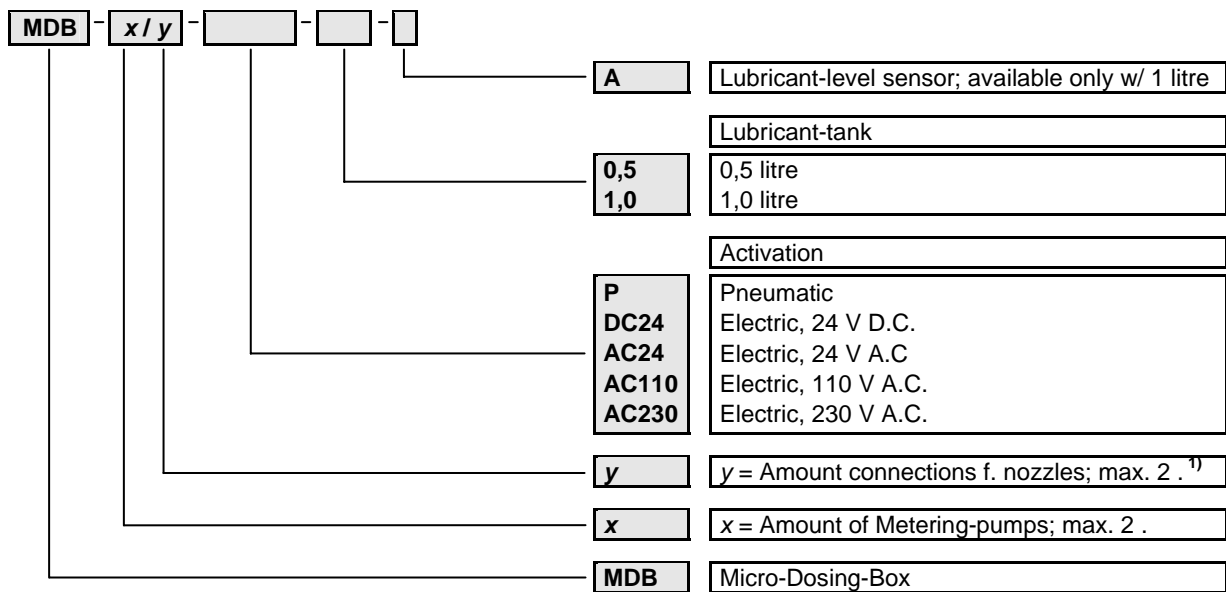

Example: **MDB-1/2-DC24-1,0-A**

- (1x) Metering-pump
- (2x) Connection for Metering-nozzles<sup>1)</sup>
- Activation: DC 24 V
- Lubricant-tank: 1litre
- Level sensor

### Note:

- The nozzles are separately configured. See separate data-sheet for Metering-nozzles.
- Information for installation, usage and adjustment can be read in the user's manual.

<sup>1)</sup> A Metering pump can supply two connections for Metering-nozzles (coaxial housing connections). The throughput is equally distributed to each nozzle.

<sup>2)</sup> see separate data-sheet for Metering-nozzles